



FLIGHT MANUAL G 102

ASTIR CS

II

The Manual belongs to ASTIR CS 77

Registration Number Works Number

Manufactured by: Burkhard Grob Flugzeugbau
8939 Mattsies
Flugplatz Mindelheim-Mattsies
West Germany

Owner:

Published: June 1977

This manual should always be kept on board the glider

Contents	page
Ownership particulars	1
List of Contents	2
Addenda	3
Flying Limitations	4
Placards	8
Key to Cockpit Symbols	9
Flying notes	11
Water Ballast	12
Dangerous	14
Accessories provided and Centre of Gravity positions	15
Measurements	16
Weights	19
Assembly	25
Control Checks	26
Maintenance	27
Inspection Procedures for increase of service time	29

1. Addenda

Current number	Page	Reference	Date	Signature
Addenda for ASTIR CS				
1	3,4,5, 7,8	changed	22. 5. 76	
2	3,4,5,6 14,16,17	changed	3. 1. 77	
3	25a	new page	1. 6. 77	
4	20	new page	26. 7. 79	
5	3,28	changed	4. 5. 81	
6	2,3,29	changed and new page	30. 9. 81	
7	3,26a	Inspection of the airbrake locking lever	25.3.85	
Addenda for ASTIR CS 77 and ASTIR CS Jeans				
1	4,5,7,8, 9,11,12 13,19,26	Remarks for retractable gear and waterballast deleted for ASTIR CS Jeans	1. 6. 77	
2	25a,	new page	1. 6. 77	
3	25	changed	1. 8. 77	
4	20	new page	26. 7. 79	
5	3,28	changed	4. 5. 81	
6	2,3,29	changed an new page	30. 9. 81	
7	3,26a	Inspection of the airbrake locking lever	25.3.85	

Flying Limitations

Airspeed Limits (I.A.S.)

	km/h	mph	kts
Never exceed (V _{NE})	250	155	135
In rough air (V _B)	250	155	135
Manoeuvring (V _A)	170	105	92
On aerotow (V _T)	170	105	92
On winch tow (V _W)	120	74	64
Airbrakes	250	155	135
Gear extended	250	155	135

A.S.I. Colour Code

33 – 92 kts – Green Border – 60–170 km/h

92 – 135 kts – Yellow Border – 170–250 km/h

At 135 kts – Red Strip – bei 250 km/h

Weights

	lbs	kp
Empty Weight	circa 594	270
Maximum permitted weight		
without water-ballast	836	380
with water-ballast	990	450
Maximum permitted weight		
of non-supporting parts	528	240

Weak Link on Winch cable

Maximum Load	1100	500
--------------	------	-----

Cloud Flying and simple Aerobatics

Permitted if water-ballast is not being carried

See pages 12 – 14

Classification Group

Standard Class (German N)

Centre of Gravity positions

Levelling means with a 1000:40 Incidence Board set up horizontal on the top of the rear fuselage.

Datum Line (D. L.) Front edge of wing at root

Maximum forward position of C. of G. 310 mm behind D. L. (12,20 in)

Maximum rearward position 480 mm behind D. L. (18,90 in)

Loading Limitations ASTIR CS 77

Empty weight of glider and maximum cockpit load, see page 7.

Minimum cockpit load: 154 lbs (70 kp)

The permissible all up weight must NEVER be exceeded.

Maximum all up weight

without water-ballast	836 lbs	(380 kp)
-----------------------	---------	----------

with water-ballast	990 lbs	(450 kp)
--------------------	---------	----------

The weight of water-ballast is dependent on the cockpit weight (Pilot with parachute and luggage). See page 7.

Weight deficiencies should be corrected by securing or removing some ballast in the seat.

The C. of G. of the pilot with a parachute on lies 485 mm in front of the Datum Line.



British Gliding Association

Flight Manual Supplement

Ref BGA 2007/01-02/2289 issue 1

Registration	BGA Number	Manufacturer and type	Serial Number
G-DDOE	BGA 2289	Grob Astir CS77	1636

Title: BGA Operations

Subjects: Extended Weight Operations
Revised Weak Links
Revised Launch speeds
Revised Operational Limitations

Reference: BGA 2007/01 issue 1 (as applicable)
BGA 2007/02 issue 1 (as applicable)
BGA Data Sheets

Applicability: Sailplanes and Self Sustaining Sailplanes issued with a BGA Certificate of Airworthiness prior to 28 September 2008 and transitioned to EASA C of A.

Conditions: The above aircraft, subject to applicability, is approved for operation in accordance with the applicable BGA Data Sheet, as amended.

Any limitation revised or amended by an EASA approved Airworthiness Directive shall have precedence over this flight manual supplement.

Any aircraft operating within the BGA Extended Weight category shall be re-classified as "Utility" - Non Aerobatic, whilst within the extended weight range.

Refer to the BGA Data Sheet for revised limitations.

Approved by the EU commission as a 14(6) derogation dated 4 July 2008, to EC regulation 1592/2002 and 1702/2003 as being compliant with the requirements of Part 21 for continued use on UK registered gliders. Subject to the above applicability and conditions.

Issued by:
British Gliding Association Ltd,
Kimberley House,
Vaughan Way
Leicester
LE1 4SE

10 July 2008

BGA glider data sheet - Astir CS77 & Jeans

Data source: Manufacturer's Handbook

Date of issue:

Manufacturer: Grob Present Type Certificate holder: LTB Lindner, website www.ltb-lindner.com.

UK Agent: Soaring Oxford Email: soaring.oxford@virgin.net Phone: 01636 525318 Fax: 01636 525287

Link to mandatory mods: www.ltb-lindner.com/g-102-ad-sb.html

Weighing Data:

	Kg	Pounds
Max weight (dry)	380	838
BGA concession non-aerobatic max weight (dry) [+3%]	391	863
Max weight with water (CS 77) No water in the Jeans Astir	450	992
Max weight of non-lifting components (everything except wings)	240	529
BGA concession non-aerobatic max weight of non-lifting components [+5%]	252	556
Max pilot weight (seat load)	110	242

C of G limits mm inches

	mm	inches
Forward C of G limit (aft of datum)	310	12.2
Aft C of G limit (aft of datum)	480	18.9
Pilot position (forward of datum)	475	18.7

Longitudinal datum: Wing root LE (not the fairing).

Horizontal datum: Rear fuselage top 1000:40 tail down

Control deflections in mm

	Up	Down	Distance - hinge to measuring point	Max free play
Ailerons	93 ±10	48 ±5	215	
Elevator	60 ±6	54 ±6	170	
Rudder	Left 190 ±10	Right 190 ±10	374	

Control surface weights & moments

CS77 No 1601-1698 Jeans No 2001 - 2092	Moment cm Kg	Weight Kg
Elevator	10,00-15,00	2,40-3,25
Rudder	16.5±10%	4.5±10%
Ailerons	16.0 ±12%	4.1±12%
CS77 No 1699 on Jeans No 2093 on	Moment cm Kg	Weight Kg
Elevator	10,00-15,00	2,40-3,25
Rudder	0 - 5,00	Max 6,00
Ailerons	0 - 1,00	Max 6,00

Maximum speeds

	Knots	Kph
VNE	135	250
Rough air	92	170
Manoeuvre	92	170

	Knots	Kph
Aerotow	92	170
Winch / auto tow	65	120

Max winch weak link: 550 Kg (BGA figure blue, 600Kg)

Tyre pressure: 36 PSI 2.5 bar (tail wheel 22-26 psi)

Semi aerobatic and cloud flying permitted (without water). Water ballast to be jettisoned before landing.

This sheet compiled by: Tim Macfadyen

Date: 25 February 2002

Update 21 April 2011 Type Certificate holder changed

Update 24 April 2011 Elevator mass balance and weight limit changed as SB 306-34

Update 29 May 2011 Max rough air speed reduced as per the TCDS

Updated 11 May 2015 "Water ballast to be jettisoned before landing" added & max landing weight clarified.

*British Gliding Association***Major Modification Application – Glider/SSS.**

For mod applications on pre 28/9/07 gliders only

BGA Mod No.
BGA 2007/02
BGA USE ONLY

Aircraft Type Various	Name & Address of applicant	Applicants Mod Number
Reg. No. BGA	BGA Generic Modification	BGA 2007/02
Serial No	Tel	Issue No 1
		Date 18/10/2007

Details of Modification (use continuation sheets if necessary)
To approve the BGA extended weight operation on BGA approved types.
Details of aircraft types and limitations are in the applicable BGA Data Sheet.
This modification allows an increase of up to 3% of max weight (and an increase of up to 5% of non lifting parts when specified)
The aircraft is classified as NON AEROBATIC whilst operating in the extended weight category.
Only pre 28 September 2007 BGA Gliders may use the BGA Extended Weight Operation.
Flight Manual Supplement: BGA 208

Suitable for installation on this aircraft only - Suitable for installation on any other glider as specified on the BGA Data Sheet		Limitations, Conditions, Exemptions See Data Sheet	
Weight & C of G Schedule Yes	Flight Manual Amendment Yes	Maintenance Manual Amendment No	Electrical Load Analysis N/A
Modification Instructions N/A	Modification Drawings N/A	Parts list N/A	Published in TNS. N/A

Can this modification be passed on to interested members within the BGA? Yes / No
~~Or - All enquires to be directed to originator.~~ (The former will apply if no preference is shown)

The above modification has been approved for incorporation on gliders/SSS registered with the BGA prior to 28/09/2007 only.

Name of BGA investigating engineer... **Technical Committee..**

BGA Technical Committee approval Yes / No* Report Completed **Yes / No / N/A***

Signed...  ...Hammerton.....For BGA

Date... 18/10/2007...

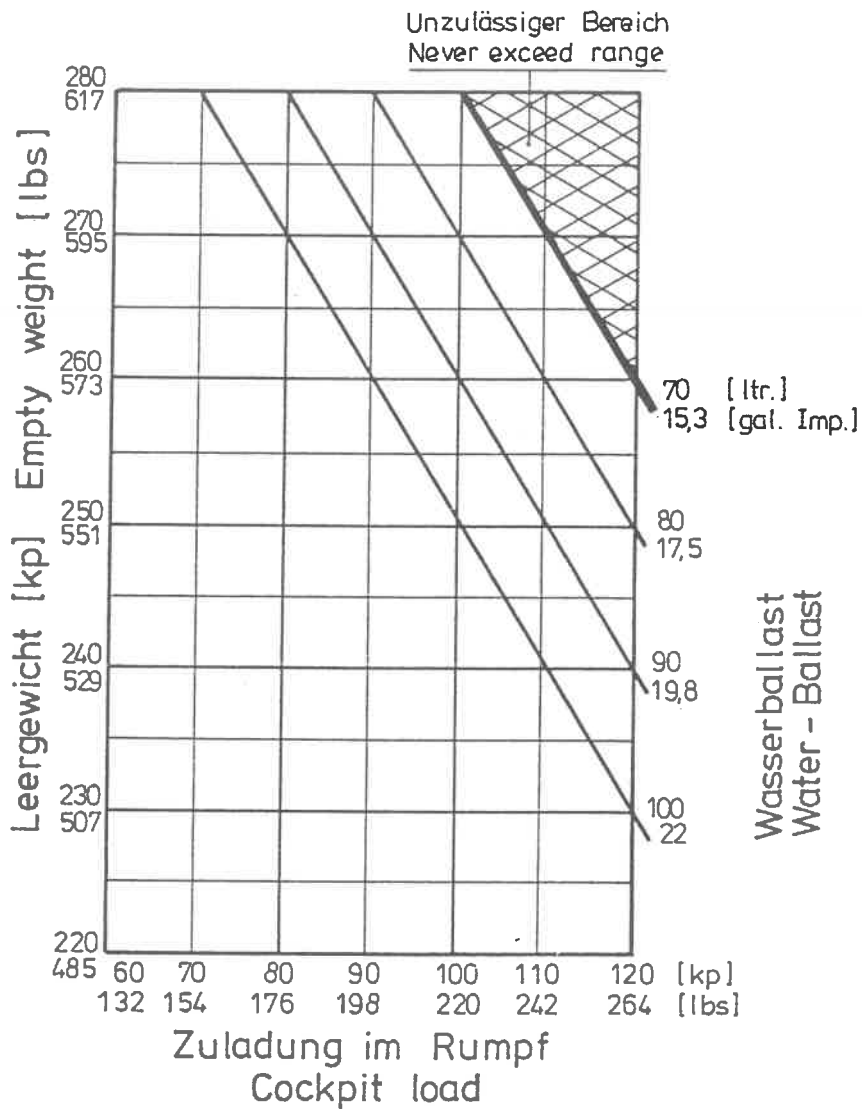

Placards to be displayed in cockpit:

Maximum weight	kp	lbs
without water ballast:	380	836
with water ballast:	450	990
Airspeed limits	km/h	m.p.h. knots
Never exceed	250	155 135
In rough air	250	155 135
Manoeuvring	170	105 92
On aerotow	170	105 92
On winch tow	120	74 64
Airbrakes	250	155 135
Gear extended	250	155 135

Payload (pilot and parachute)

The maximum weight must not be exceeded.

Minimum payload: 70 kp, 154 lbs.

Less weight must be compensated with ballast in the seat.

Placards to be displayed near undercarriage:

Weak links for towing
500 kp, 1100 lbs. max.
Tire: 2,5 Atm., 36 psi

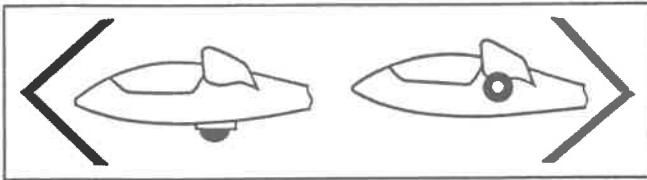

DOWN Under-carriage UP
Handle moves in slot on right of cockpit

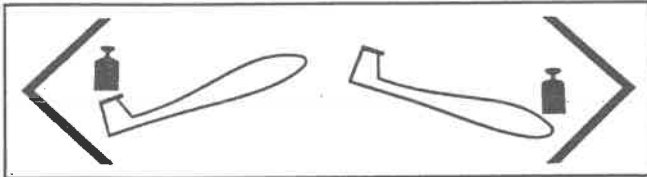

Trimmer
On left of cockpit. GREEN lever.

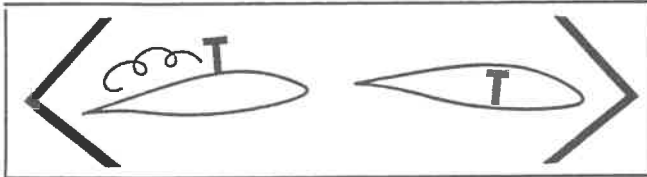

Air-brakes
On the left-hand side of the cockpit. BLUE handle.

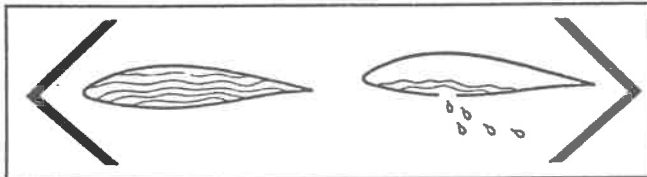

Water-ballast Jettison
On the right of the cockpit. WHITE lever.

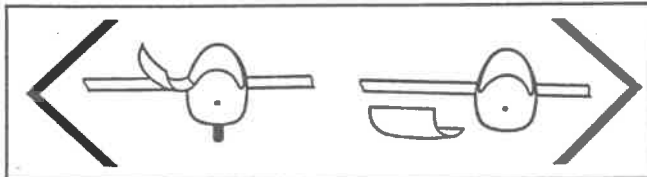

Canopy
Round RED knobs. Left of canopy-frame OPEN. Right of canopy-frame JETTISON



Pedal Adjustment
Small BLACK knob on the top of the instrument panel. (right hand)

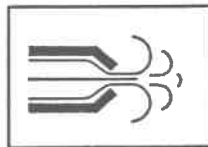

Air-vent
Small BLACK knob on the top of the instrument panel. (left hand)

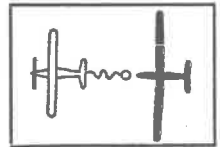

Cable Release
In front of the stick on the left. YELLOW knob.

Graph of True v. Indicated Airspeed, showing the effect of Position Errors. When the A.S.I. is connected to the following pressure sources.

A.S.I. — Pitot head in tail fin static vents side of the Fuselage before the wing root.

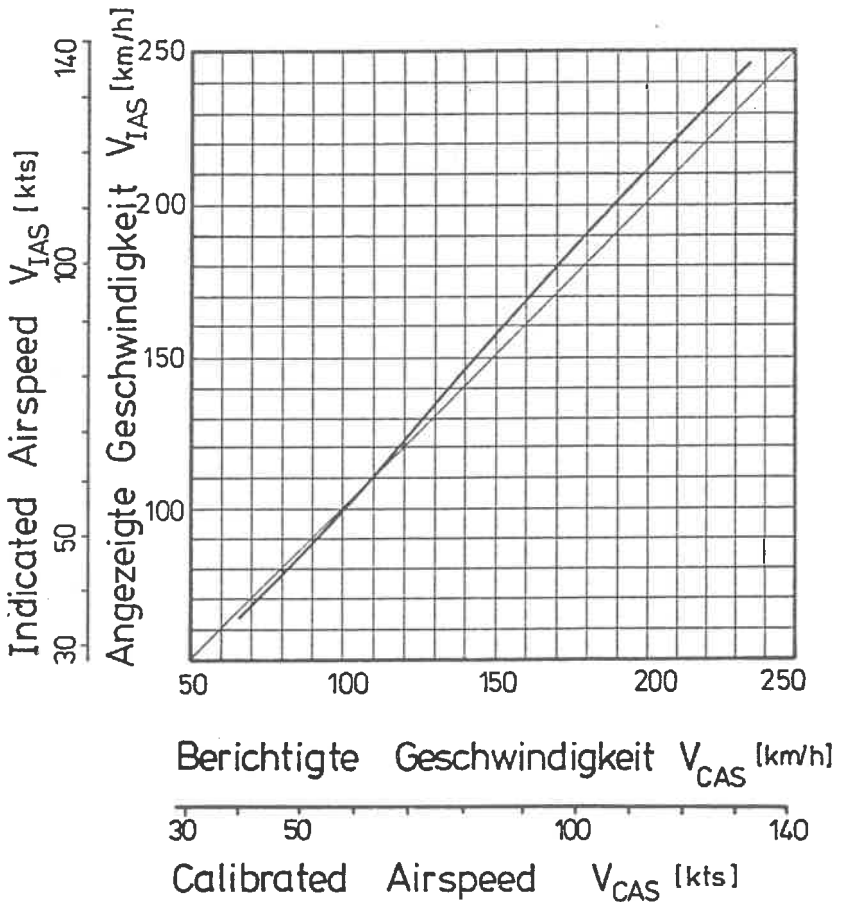

Notes on Flying the Glider

Winch/Auto-tow-Launch

Maximum permitted launch speed: 64 kts

The glider has a belly-hook in the undercarriage well in front of the wheel.

A cable launch presents no difficulties with any C. of G. positions or weight configurations. The glider has no tendency to balloon and is very stable on the launch. Up to a height of 300ft the nose should be held down if the launch is fast.

Aerotow

Maximum permitted towing speed: 92 kts

The glider's C. of G. position allows the areotow to be carried out using either the nose — or belly-hook. During the whole of the time on tow, the glider can be easily controlled with rudder and aileron, full movements of which can be used if necessary. Even in strong cross-winds the glider shows no tendency to wander around. At 32 kts the glider can be lifted off: with 37 — 40 kts indicated, the glider climbs on its own. The undercarriage can be retracted whilst still on tow. The yellow release knob is positioned on the left in front of the stick, and should be pulled fully back when releasing the tow-rope.

Weak Link in tow-rope

Maximum load: 1100 lbs

Rudder-pedal Adjustment

To adjust the rudder pedals, push lightly forward on them with the heels and disconnect the locking device by pulling the handle on the instrument panel. The pedals move towards the pilot by themselves: to adjust them forward you have to push them against the pressure of the springs with your heels. The pedals will lock themselves in the position required when the handle is released.

Canopy

The single-piece perspex canopy has a clear-vision panel and ventilation port, and is fitted an hinges. The handle for opening it is located on the left-hand side of the canopy surround: that for jettisoning it on the right-hand fuselage side. To jettison the canopy, pull both handles back and push it up and away with the left hand.

Retractable Undercarriage

The undercarriage control lever is located on the right of the cockpit. When retracted or lowered, the wheel should be locked in place by pushing the control lever in towards the fuselage side.

Air-brakes

The lever for the air-brakes is situated on the left-hand side of the cockpit. Before beginning a launch, check that the air-brakes are closed and locked. One should avoid trying to land with full brake out, since the effectiveness of the brakes means that the glider is descending fast.

Wheelbrake

The lever for the wheelbrake is located on the stick.

Trimmer

The built-in trimmer can be progressively adjusted. The control lever for it is positioned on the left-hand side of the cockpit behind the air-brake lever.

Trim range from 32 kts — 97 kts.

Flight with Water-ballast

The glider has the same all up weight as a standard 2 seater glider, when loaded with water-ballast and a full cockpit load. The slow flight and stalling characteristics of the fully loaded glider are a little different from one flown without water-ballast.

The stalling speed will be increased to 38 kts.

Also larger control movements will be necessary.

The glider will spin cleanly but will recover immediately spin recovery action is taken.

The pilot is advised to have extra height when slow flying or approaching to land while carrying water-ballast.

Use of Water-ballast

The water-ballast tanks are situated in the front part of the wings, from the root outwards. Each wing can hold 50 litres. The tanks are filled through an opening in the top surface of the wing. This is covered by a plug, which can be removed by screwing in a bolt. The water is drained off through an opening in the underside of the fuselage behind the wheel-box. To open the valves of the tanks, the control lever on the right-hand side of the cockpit should be pulled backwards. It takes about 3 minutes for the tanks to empty themselves.

Air from the tanks escapes through the overflow pipe that runs down to a point on the underside of the wing near the root. When flying with water-ballast the connecting-tape that covers the gap between fuselage and wings, should be folded back on the underside in the region of the spar, so that any excess water which may appear runs out rather than down into the fuselage.

During long flights at an air temperature of 0 ° C (32 ° F) the water-ballast must be jettisoned because there is danger of collapse of the ballast tanks.

When a field landing is to be made the water-ballast must be jettisoned.

The glider must not be parked over-night with water-ballast on board. If the glider has to be towed for a long way on the ground with water-ballast on board, the tanks should be emptied.

When de-rigging the water-ballast tanks will empty themselves through the wing root connecting pipes.

Stalling Characteristics

Warning of the stall occurs at a speed of 32-35 kts (depending on wing loading), when the top of the tailunit begins to shudder. If the stick is pulled back even further, the glider „mushes“ but remains controllable, it being possible to make turns up to an angle of bank of 20° without the wing dropping away. If the stick is released the glider returns immediately to the normal flying attitude. If the stick is pulled back quickly, the nose will drop away but any tendency for a wing to fall can be controlled by the rudder.

Aerobatics

Permitted manoeuvres and speeds at which they should be initiated:

Loop	92 kts
Chandelle	92 kts
Steep turn	65 kts
Lazy eight	65 kts

Spins:

From the fully stalled position, put on full aileron and rudder (crossed). Keep the stick back. To stop the spin centralize or release one of the controls. Height lost per rotation is approximately 220 ft. The speed reached when levelling out is about 86 kts.

Maximal positive g loading + 5,3.

Manoeuvres that involve negative g loads are prohibited.

Unorthodox manoeuvres are likewise prohibited.

Spinning

With the Center of Gravity between 415 mm and 480 mm behind the Datum Line, it is possible to put the glider into a spin from the stalled position. To do so the stick has to be pulled fully back, and the rudder and aileron controls be fully crossed. The nose will then drop in the direction in which rudder is being applied, and with a rearward C. of G. position the glider will rotate in a slow, flat spin.

Recovery from the spin can be effected in any way you choose. With almost all C. of G. positions and wingloadings all that is required is for one of the controls to be released or returned to its normal position. The quickest recovery (without overstressing the glider) can be brought about by centralizing all of the controls.

The height lost in returning to the normal flying position after a single-rotation spin, is about 220 ft.

If the glider fails to stop spinning immediately the controls have been centralised, then the standard method of spin recovery should be employed at once:

- 1 Full opposite rudder
- 2 Pause
- 3 Stick steadily forward
- 4 When spin stops, centralize controls and resume normal flight

Speed Flying

In speed flying it is quite possible to exceed the maximum permitted speed. At very high air speeds, care should be taken to use only small control movements so as not to overstress the glider:

Dangerous

Escape Procedure

In the event of having to bail out, the following procedure should be followed: —

- a) Pull both red knobs back on right and left of canopy surround and with left hand push canopy upwards and backwards.
- b) Umbuckle seat harness.
- c) EXIT over left or right side.
- d) Wait only 1 – 3 seconds before pulling the rip cord.

Flying at High Speed

Within the permitted speed range the glider has no tendency towards high speed flutter. The controls need only be used at $\frac{1}{3}$ of their full

- 4 Four piece safety harness
- 5 Weighted seat cushion at least 2³/₄" , thick, or parachute
- 6 Loading limitations Chart
- 7 Flying limitations Placard
- 8 Flight Manual

Weight and Center of Gravity positions

When the new instruments are added and other changes in the weight of the glider made, the empty weight C. of G. position should be checked. If the limits of the empty weight C. of G. positions and the Loading Limitations Chart are adhered to, then the C. of G. of the loaded glider will lie within the permitted range.

Empty Weight (lbs)	Range of C. of G. positions (mm behind the Datum Line)
539	697 – 756
550	690 – 750
561	683 – 745
572	675 – 740
583	654 – 735
594	633 – 730
605	612 – 726
616	593 – 721
627	574 – 717

Measurements

Position of the glider whilst taking all measurements:
with a 1000:40 Incidence Board set up horizontal on the top of the rear fuselage.

Elevator	upwards	2.36 ± 0.23 in	60 ± 6 mm
	downwards	2.13 ± 0.23 in	54 ± 6 mm
Rudder	left	7.48 ± 0.39 in	190 ± 10 mm
	right	7.48 ± 0.39 in	190 ± 10 mm
Aileron	upwards	3.66 ± 0.39 in	93 ± 10 mm
	downwards	1.89 ± 0.20 in	48 ± 5 mm
Angles:	between the center line of the wing and the longitudinal axis of the fuselage		2°
	between the cord of the tail-plane and the longitudinal axis of the fuselage		0°

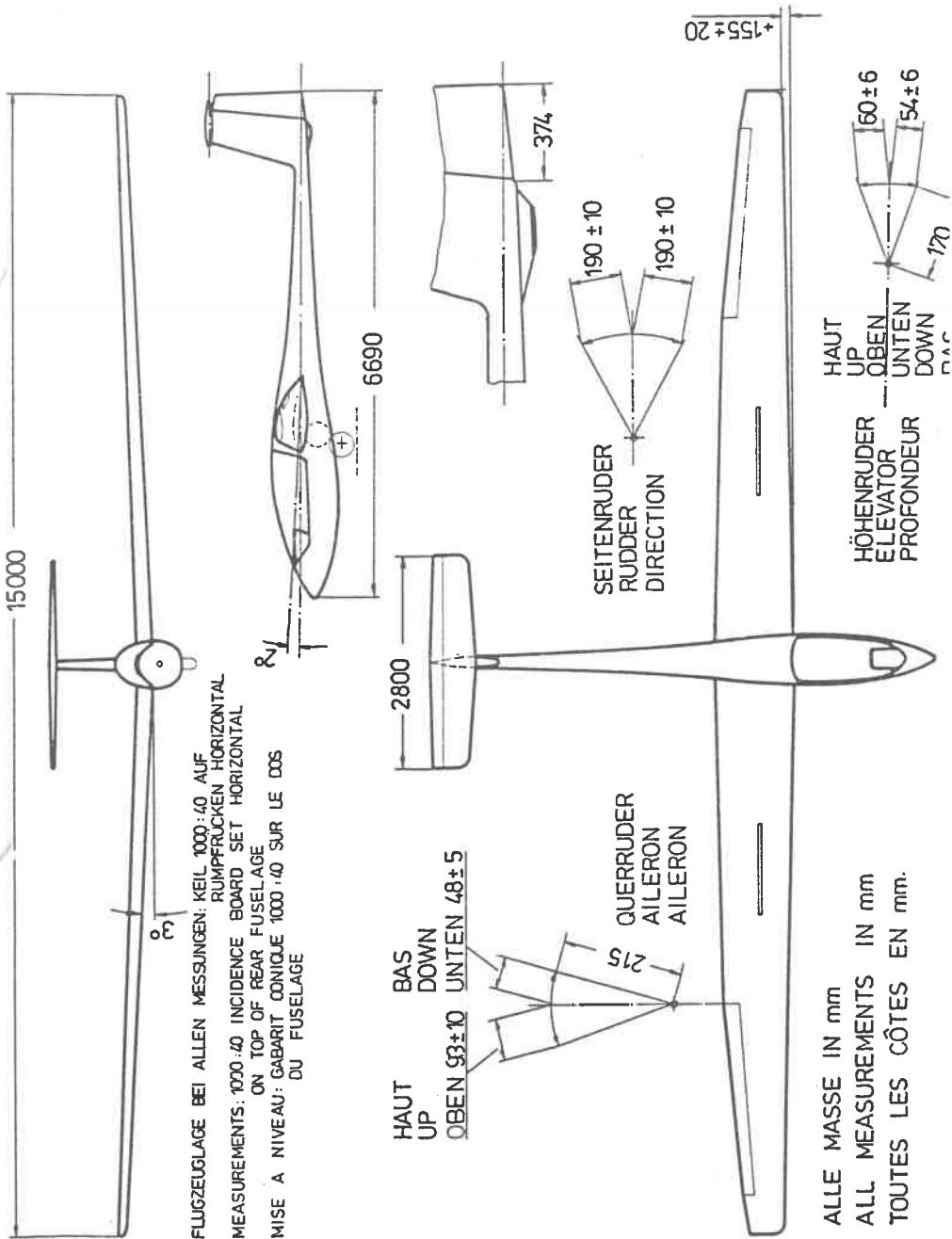

FLUGZEUGLAGE BEI ALLEN MESSUNGEN: KEIL 1000 : 40 AUF RUMPFBRÜCKEN HORIZONTAL
 MEASUREMENTS: 1000 : 40 INCIDENCE BOARD SET HORIZONTAL ON TOP OF REAR FUSELAGE
 MISE A NIVEAU: GABARIT CONIQUE 1000 : 40 SUR LE DOS DU FUSELAGE

ALLE MASSE IN mm
 ALL MEASUREMENTS IN mm
 TOUTES LES CÔTES EN mm.

Performance	350 kp	450 kp
Best Glide Angle	37,3 — 95	38 — 105 km/h
Minimum Sink (meter/sec)	0,6 — 75	0,7 — 85 km/h
Circling speed	80 — 85	90 — 95 km/h

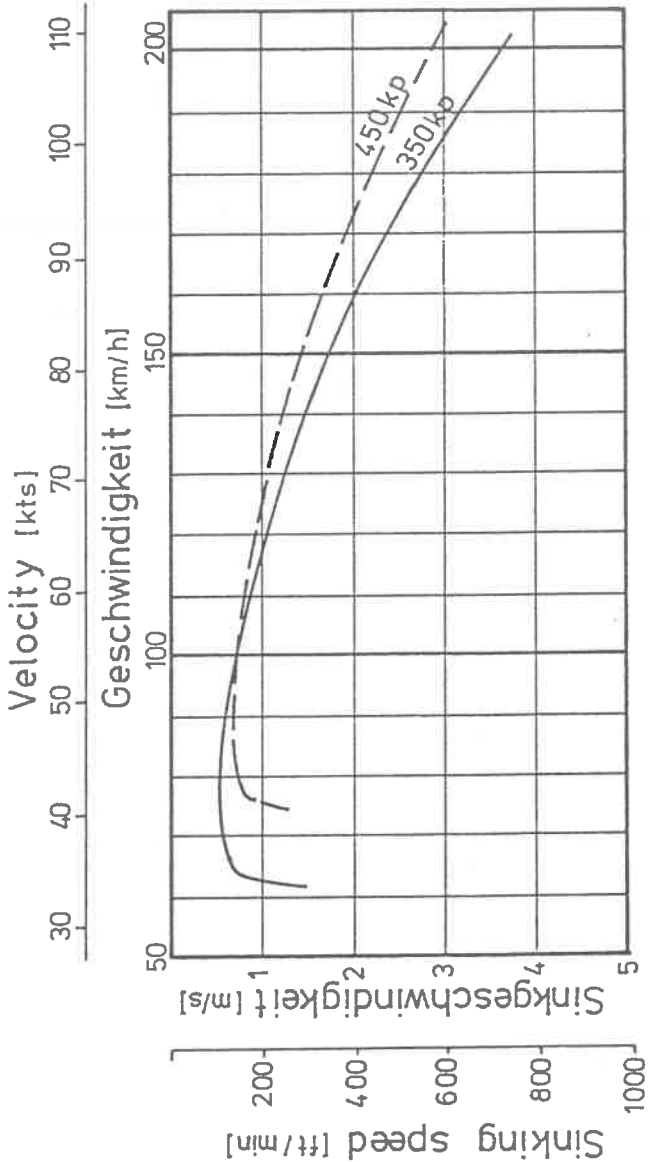

Geschwindigkeitsspolare ASTIR CS
Flight Polar

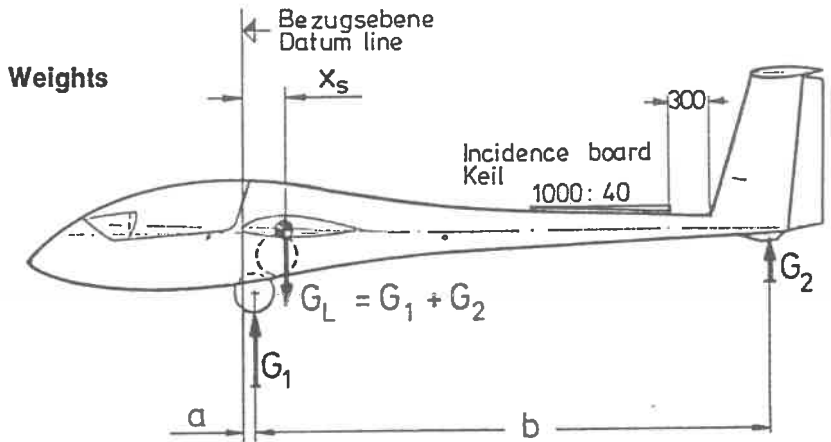

Datum Line: Front edge of the wing at the root

Levelling means: With a 1000:40 Incidence Board set up horizontal on the top of the rear fuselage.

Weight on main-wheel $G_1 =$ lbs

Weight on tail-skid $G_2 =$ lbs

Empty Weight $G_L = G_1 + G_2 =$ lbs

Displacement of main-wheel $a =$ mm

Displacement of tail-skid $b =$ mm

Empty Weight C. of G.

$$X = \frac{G_2 \times b}{G_L} + a = \text{---} + = \text{---} \text{ mm behind Datum Line}$$

Maximum Load $G = 836 - G_L =$ lbs

The measurements to determine the empty weight, the empty weight C. of G., and the loading limitations should always be taken with the glider empty of waterballast.

VI. Weights and moments of the control surfaces

The weights and the moments of the control surfaces must not exceed the following values:

ASTIR CS (Serial No. 1002 – 1536)

Elevator:	12,0 cm kg \pm 10%	2,7 kg \pm 10%
Rudder:	13,65 cm kg \pm 10%	3,2 kg \pm 10%
Aileron:	16,0 cm kg \pm 12%	4,1 kg \pm 12%

ASTIR CS 77 (Serial No. 1601 – 1698)

ASTIR CS JEANS (Serial No. 2001–2092)

Elevator:	12,0 cm kg \pm 10%	2,7 kg \pm 10%
Rudder:	16,5 cm kg \pm 10%	4,5 kg \pm 10%
Aileron:	16,0 cm kg \pm 12%	4,1 kg \pm 12%

ASTIR CS 77 (from Serial No. 1699)

ASTIR CS JEANS (from Serial No. 2093)

Elevator:	12 cm kg \pm 10%	2,7 kg \pm 10%
Rudder:	0 – 5 cm kg	max. 6 kg
Aileron:	0 – 1 cm kg	max. 6 kg

The moments must be measured with the control surfaces removed. To determine the moment $M = P \cdot r$ the surface should be mounted at the hinge line with the minimum friction possible. The force P can be measured, for example, using a letter scale. If these values are exceeded the mass balance should be increased. Before carrying out repairs which for example involve charging the mass balance on a surface the manufacturer or his repair agent should be consulted.

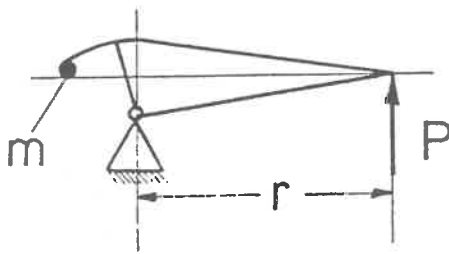

Assembly

It is possible to rig the glider with three people.

1. Wings:

Open the 4 main wing fittings in the fuselage. Unlock the air-brakes on the wings. Guide the right wing into the fuselage. The safety catches on the fuselage sockets will be released, and on gently moving the wing to and fro will be heard to snap into place. Next guide the left wing into the fuselage. Move the wing tips up and down so that the pin on each spar stub is located in the appropriate hole in the opposite wing root. Next the catches on the left-hand fuselage sockets should be released, and by moving the wing backwards and forwards they too can be made to snap into place. To ensure that the wing-fuselage joint is safely secured, turn the socket catches towards the bayonets until they drop into place.

Checks

The red circles on the fuselage sides must be covered by the rotated sockets.

2. The aileron and brake-connections lie behind the spar.

The short connecting rods in the fuselage are fitted with quick-action locks which must be coupled up to the knobs of the push-rods that move inside the wings.

After rigging, the connecting rods should be examined to check that pins are properly inserted, and project some mm out of the locks.

After coupling the quick action locks, check that the ball can not be extracted, by twisting the lock back and forth. Do this gently with not more than 10 lbs pull. Check all control connecting rods and locks in a methodical order.

After rigging the following check must be carried out to check the connections are secure:

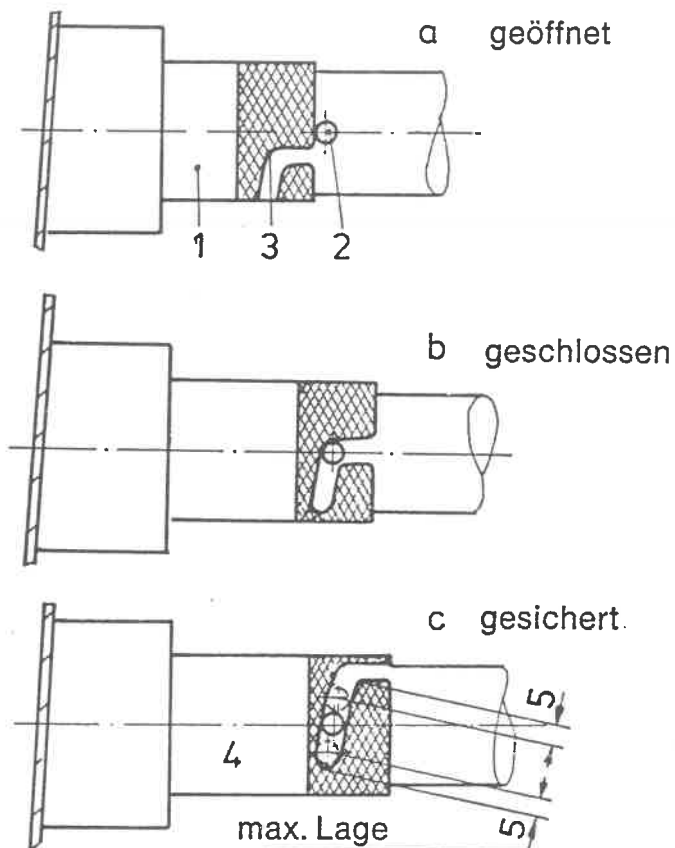

After connecting the quick lock couplings make a visual check that the collar is extended forward over the bearing far enough for the safety pin to engage.

3. Tailplane:

Before assembly is commenced the front cover must be removed and the rotating knob pulled out to the limit. The tailplane can then be positioned by one person, who should stand behind the rudder. The tailplane can be rested on the top of the fin with the elevator angled upwards, so that the snap-lock fastener on the elevator push-rod can be attached to the ball on the elevator. The front of the tailplane can then be lowered and pushed back into three pins. It is then necessary to turn the knob to the right to conclude installation. The assembly is complete when the knob is turned so far that there is no play in any direction. The cover provides a safety measure as it can only be attached with the knob in the horizontal position. If necessary the knob has to be turned 1/4 turn to suit. Disassembly is carried out in the reverse order and the knob is turned to the left and pulled.

Checks to be made after assembly

- 1 Check that the 4 main wing fittings are locked.
- 2 Check that aileron and brake quick-action locks are properly located on the knobs.
- 3 Ensure that the tow hook is functioning correctly.
- 4 Test the operation of the wheelbrake and the pressure of the air in the tire.
- 5 Check that the tailplane is securely seated and that the elevator push-rod is connected.
- 6 Rudder movement.

Pre-Launch checks

- 1 Do all the controls move freely?
- 2 Are the air-brakes locked?
- 3 Is the undercarriage control lever in the most forward position and is it pushed in flush with the fuselage-wall?
- 4 Is the trimmer set at neutral?
- 5 Is the canopy locked?
- 6 Are the parachute and seat straps drawn in tight and secured?
- 7 Is the altimeter set to ZERO or the height of the airfield?
- 8 Is the radio turned on and set to the frequency being used by the airfield control?

Inspection of the airbrake locking lever

At the daily check the right- and lefthand airbrake locking levers have to be checked through the inspection openings in the wing underside.

The lever are made of aluminium casting and have a facilitating hole. The following instruction has to be carried out: Inspection of the airbrake locking levers for cracks in one of the 3 legs.

For a better inspection the plexiglass-pane can be removed for easier access. The use of a magnifying glass is recommended.

If cracks are found, the exchange of the locking levers left- and righthand no. 102-4123/4124 of aluminium casting for such of aluminium sheet (see TM 306-26) is required.

If the aluminium sheet's are installed, the daily check is not longer applicable.

Maintenance

The greatest care should be taken in maintaining the **fibre glass surface** of the glider. Luke warm water should be used to wash off dust, grease, dead flies and other dirty marks. More resistant dirt should be removed by using a mild cleaning agent. Only special silicon-free preparations should be used in maintaining the painted surfaces. Cracks should be carefully filled.

Although very resistant the glider should be protected as much as possible against **rain and dampness**. Water that has seeped-in should be dealt with by storing the glider in a dry place, frequently turning over the dismantled parts.

The most effective way to clean the **canopy** is to use a special perspex cleaner, but if necessary luke warm water can be used. A soft, clean cloth or chamois-leather should be employed to wipe the canopy down. Never rub perspex with anything dry.

The Safety harness should be regularly checked for mildew and general wear and tear. The metal parts of the harness should be frequently checked for rust.

Because of its position in the wheel cavity **the tow-hook** is susceptible to getting very grimy and muddy. It must therefore be frequently inspected for damage, cleaned and greased. When the seat-well is removed the hook can easily be taken out. Remove the connecting wire from the lever and take out two retaining screws. For reconditioning the tow hook should be sent with the record card to the tow hook manufacturer, Tost.

The main wheel **tire pressure** should be kept at $2\frac{1}{2}$ atmospheres (36 psi).

The wheelbrake is of the drum type. If required the point at which the brake begins to drag can be adjusted. The adjustment is carried out by moving the Bowden cable at the drum end.

When **the main wheel is being taken off** for the purpose of cleaning, greasing or changing the tyre, the Bowden cable should be disconnected from the brake-lever. Screw the M 6 threaded special tool onto one side of the axle and take out the screws and the spindle. Remove the screws that hold the brake-lever in place. Take the wheel out by pulling it downwards. Clean all the parts and before re-assembly smear all of them with grease.

Before assembling the glider **the pins and sockets** at the joints between wings and fuselage, and tailplane and fuselage, should be cleaned and greased.

If **repairs** are carried out on the glider which are more extensive than normal maintenance work, the manufacturers should be contacted.

It is absolutely essential to ensure that if the glider is **re-painted** all surfaces which are directly exposed to the sun's rays should be painted **WHITE**.

When any repairs are done or a fresh coat of paint added the position of the empty weight C. of G. must be re-checked.

Maintenance on Hotellier quick-locks must be conducted during each annual inspection or 500 hours whichever ever occurs first. They are installed at the control-connections of aileron and airbrakes at the wing-fuselage joint and at the elevator connection to the pushrod.

The diameter of the swivel has to be measured at different points by a micrometer with no differences in excess of 0,1 mm (0,004 in.) that means the swivel must still be spheric. If there are large differences the swivels and appropriate joints must be replaced.

Swivels and joints should be greased prior to each rigging.

The use of additional safety-pins guided through the holes of the wedge-type slides increases safety. (safety-pins No. 500 3771 from A. Würth, D - 7118 Künzelsau, W.-Germany or manufacturer)

Inspection Procedures For Increase of Service Time

1. General

The results of fatigue tests of wingspar sections have demonstrated recently that the service time of FRP gliders and motorgliders may be extended to 6000 hours, if for each individual glider (in addition to the obligatory annual inspections) the airworthiness is demonstrated according to a special multi-step inspection program particularly with regard to the service life.

2. Dates

When the glider has reached a service time of 3000 hours, an inspection must be done in accordance with the inspection program mentioned under point 3. If the results of this inspection are positive or if any defects found have been duly repaired, the service time of the glider is extended by another 1000 hours to a total of 4000 hours (first step).

The above inspection program must be repeated when the glider has reached a service time of 4000 hours. If the results of this inspection are positive or if any defects found have been duly repaired, the service time of the glider is extended to 5000 hours (second step).

When the glider has reached a service time of 5000 hours, the above inspection program again must be repeated. If the results of the inspection are still positive or if any defects found have been duly repaired, the service time may be extended to a total of 6000 hours (third step).

For a possible service time exceeding 6000 hours procedures will be evaluated in the future.

3. In each case the latest issue of the inspection program which will be updated according to incoming inspection results, has to be ordered from the manufacturer.
4. The inspection must only be done by the manufacturer or by a licensed repair station or inspector.
5. The results of the inspections have to be recorded in an inspection test report wherein comments are required for each inspection instruction. If the inspections are done outside the manufacturer's facilities, a copy of the records must be sent to the manufacturer for his evaluation and information.
6. The annual inspection is not affected by this inspection program.



REPAIR INSTRUCTIONS
FOR GLIDER G 102

ASTIR CS

Manufactured by: Burkhart Grob Flugzeugbau
8939 Mattsies
Flugplatz Mindelheim-Mattsies
West Germany

INDEX

	Seite
1 Forward	1
2 Authorized Materials and Suppliers	2
3 Simplified „Texture“ plan of ASTIR CS	4
4 Repair of GFK material	5
5 Damage to section GFK foam-sandwich	5
6 Damage to section of GFK Styropor-sandwich	7
7 Damage to section of GFK laminate	7
8 Paint-work	9
9 Repair of Metal Fittings	9
10 Major Repairs	10
11 Construction details of extra equipment attachment fittings	11

1. Forward

The Glider ASTIR CS is constructed from Glass-Fibre reinforced Plastic (GFK). The fuselage and control surfaces consist of GFK laminate. The load bearing surfaces (wings) and the Tailplane consist of GFK laminate with a foam supporting layer (GFK foam-sandwich). The Tail-fin consists of GFK styropor sandwich.

2. Authorized materials and suppliers

Resin: Shell Epikote 162

Hardener: BASF Laromin C 260

Mixing: 100 parts Resin - 38 parts Hardener

Ratio by weight

Glass Fibre Cloth

Supplier: Interglas Textil GmbH. Söflinger Str. 246, 7900 Ulm

Use	Cloth	Weight g/qm	Interglas-Nr.
Fuselage	Double Twill	161	92 110
	Double Twill	390	92 140
	Chain Reinforced	433	92 146
Wings	Double Twill	161	92 110
	Double Twill	276	92 125
	Chain Reinforced	433	92 146
Elevator and Rudder	Double Twill	276	92 125
Ailerons	Double Twill	276	92 125
	Double Twill	161	92 110

All Glass-Fibre cloth is Alcholine free. E Class with Volan-A-Finish or Finish 1.550.

Supplier:

Rovings:

EC 10-80-2400 K 43

Gevetex

4000 Düsseldorf

Postfach 1205

Foam Material

PVC-Hartschaum

Coticell 60

8 and 8 mm large

Spec. Weight 60 kg/m³

Continental AG

3000 Hannover

Styropor:

Thermopete
4 mm large
Spec. Weight 15 kg/m³

Poron-Werke GmbH
6122 Erbach
Brunnenstraße 5

Filling Material for Resin

Microballoons Brown

Lackfabrik Bäder KG
7300 Eßlingen
Schließfach 25

Cotton Flock
Type FL 1 f

Schwarzwälder Textil-Werke
7623 Schenkenzell
Postfach 12

Paint

PE-Schwabbellack
White. No. 03-69120
UP-Hardener No. 07-20510
100 Schwabbellack Paint (Gel-Coat)
3 Hardener mix ratio by Weight.
Thinners No. 06-30260

Lesonal-Werke
7000 Stuttgart 30
Postfach 30 07 09

Red Paint

Nitro-Cellulose-Kombilack
Blood-Orange RAL 2002

Lackfabrik Bäder KG
7300 Eßlingen
Schließfach 25

3. Simplified „Texture“ plan of Astir CS

Reinforced regions for special loads and stress conducting are not shown.

1. Flügel

Außenlaminat
1 Lage 92 110 diagonal
1 Lage 92 125 diagonal
Kern
Conticell 60 8 mm
Innenlaminat
1 Lage 92 125

Wing

Outer laminate
1 Layer 92 110
1 Layer 92 125
Core
Conticell 60 8 mm
Inner laminate
1 Layer 92 125

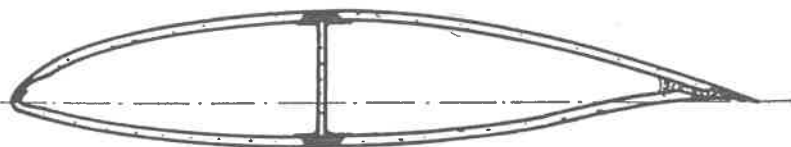

2. Rumpf

Von außen nach innen
1 Lage 92 110 längs
1 Lage 92 146 längs
3 Lagen 92 140 diagonal

Fuselage

From outside to inside
1 Layer 92 110 lengths
1 Layer 92 146 lengths
3 Layers 92 140 diagonal



3. Ruder

Höhenruder
Seitenruder
Querruder
2 Lagen 92 125 diagonal

Controis

Elevator
Rudder
Aileron
2 Layers 92 125 diagonal

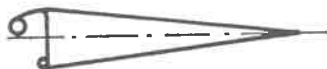

4. Höhenflosse

2 Lagen 92 110 diagonal
Kern: Conticell 60 6 mm
1 Lage 92 110 diagonal

Fin

2 Layers 92 110 diagonal
Core: Conticell 60 6 mm
1 Layer 92 110 diagonal

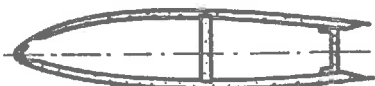

4. Repair of GFK material

If the glider is damaged, first examine the outer surface very carefully, frequently other structural parts are involved, fractures can run unseen under the outer surface.

Carry-out repairs with extreme care. Gliders of GFK, the outer surface is stressed (loading bearing) failure of this skin can lead to structural failure.

Keep to the Resin-Hardening mixing ratio exactly = 0.5% using a clean mixing pot. The ratio of Glass fibre – to Resin mix is approximately 1 to 1. Grind or splice the repair, before laying damp laminate on it, so that dirt cannot penetrate and stop safe adhesion.

As in plywood, the direction of the fibre glass cloth lay (length or diagonal) is of extreme importance to its strength. It is necessary to know approximately how many fibre and their direction in the damaged part with reference to the simplified texture plan, so it may be restored to the correct wall strength. If a small piece of the damaged laminate is broken off and burnt, the remaining glass-fibres can be counted and identified.

Splicing and grinding are time consuming, to save trouble, grind only as much away as necessary, only to the size of the cloth patch. When it is necessary to shorten the repair time it may be done with a hot air blower to speed the resin hardening time.

Warning. A too high temperature will produce large air bubbles in the cloth. A tent can be built out of foil, through which hot air can be guided, and thereby avoiding local overheating. "In making repairs to control surfaces, be careful not to increase their weight as there is danger of creating flutter conditions.;

5. Damage to section GFK Foam-Sandwich (GFK Hard-Foam-Sandwich)

It can appear that only the outer surface (the outside laminate) is damaged but it can also happen that the whole skin (outside and inside hard foam laminate) is destroyed.

a) Important

With a split or fracture, the laminate can become detached from the supporting foam. Start by removing loose laminate until firm laminate is reached. To remove the foam laminate use a grinding disk, grinding block or sharp knife. With a grinding block or sharp knife only remove the cloth around the damage. Splice ratio per cloth covering approximately 20 mm ratio laminate thickness to splice: approximately 1:50.

After grinding out the splice, the repair must be thoroughly cleaned. Remove the dirt (also out of the foam pores) with compressed air. Wash the splice with carbon tetrachloride or Acetone, in case it has been contaminated with dirt or grease.

Fill up the pores of the foam with Resin and Microballoons until it is smooth. Then join the laminates with the correct cloth, laying it in the right direction.

Repairs must be dirt grease free. (Figure 1)

At room temperature the resin will harden in about ca. 8 hours. The repair can now be ground smooth and be painted.

Warning: Grind only to the edge of the repair.

b) Damage to the whole of the Sandwich

When the inner laminate is destroyed, so there is no binding with the foam, widen the hole so far as foam material is secure, then it is possible to repair the inner laminate. A edge of at least 20 mm must be obtained (retaining laminates thickness : splice ratio approximately 1:50).

The inner laminate must be carefully ground and cleaned.

The outer laminate is repaired as described in section a). (Figure 2)

With „minor“ damage a piece of thin plywood support can be glued with Pattex from within on the inner skin, the cloth patch of the inner laminate can then be layed in and the hole filled with resin and Microballoons mixed with Styroporballs. When hardened (ca. 8 hours room temperature) the outer surface can be ground smooth and the outer cloth put on.

The plywood support should remain as part of the repair. When the hole is of large or of long size the plywood support should be held in place with thin nails which can be removed later, by pushing them out from the top surface.

Warning: The plywood support must be well jointed to avoid wrinkles in the cloth. (Figure 3)

With large holes in the sandwich, the weight of the Microballoons hard foam filler, must be considered. A foam piece is made before-hand, which exactly fits into the existing hole. The inside pores are closed with resin and Microballoons and laid on the inner cloth to harden, until the foam is just bendable (EVTL. Hot Air). Then the foam with

enthickened resin (cotton flock-Microballoons) can be glued in the hole. Microballoons are used to close the outside pores, the repair is then ground and the outside cloth is then laid on.

6. Damage to section of GFK Styropor-Sandwich

Repair of Styropor damage of section.

The Styropor has a closed upper surface, the cloth is held with pure or lightly thickened resin. Splits in the upper surface pores can be filled. With large damage put a patch inside and allow to harden first before working further. This will stop the structure wrinkling.

Warning: Do not use strong heat to speed up hardening time, for Styropor will develop blisters and the repair must be done again.

7. Damage to section of GFK Laminate

Repairs to GFK laminate are simple. Splice the laminate around the hole, lay the cloth in layers on (largest patch first) and after 2–3 hours, when the resin has partially hardened smooth over with resin and Microballoons. Splice length pro cloth layer ca. 20 mm. Retaining laminate thickness : Splice ratio 1:50. In case the splice is dirty it can be cleaned with Carbon Tetrochloride or Acetone.

With large damage a under laying support (plywood) should be used. Wet laminate should not bridge a gap of more than 20 mm unsupported. The plywood support can be held in place with Pattex glue and nails (e. g. metal fitting in fuselage) which can be removed afterwards. (Figure 4).

8. Paint-work

As soon as the laminate of the repaired section is hard, it can be rough ground with (80 grit) sandpaper. Large unevenness must be filled and smoothed with white polyester filler. Then with fine dry-grinding paper (150 grit) until a moderately smooth outer surface is produced. Before painting, the repaired section must be perfectly cleaned from grinding dust, separated mediums and other foreign bodies.

For successful painting, with Gel-Coat (Schwabbellack + hardener) a not too large brush should be used, putting on several thin coats, until the laminate can no longer be seen.

The first coat should be allowed to harden and then ground with

1 Lage 92 110
1 Layer 92 110

1 Lage 92 125
1 Layer 92 125

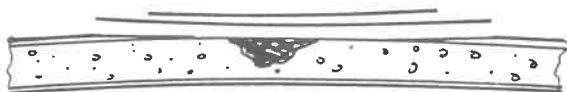

Kern
Core
Conticell 60

Microballoons

Abb. 1
Fig. 1



Abb. 2
Fig. 2



Abb. 3
Fig. 3

Rumpfschale
Fuselage skin

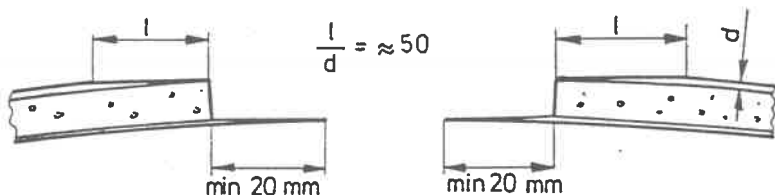
1 Lage 92 146
1 Layer 92 146

1 Lage 92 110
1 Layer 92 110

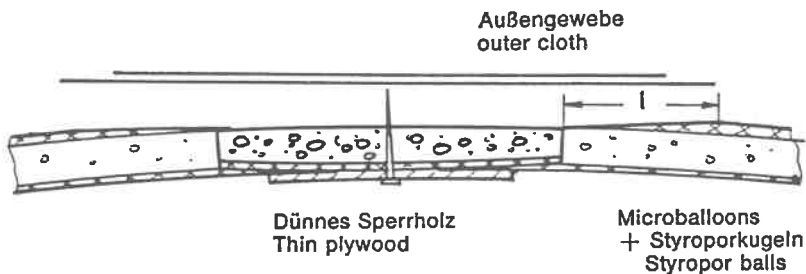
3 Lagen 92 140
3 Layers 92 140



Abb. 4
Fig. 4

(360 grit wet paper) additional coats should then be added and likewise ground.

The final finish should be carried out with 600 grit or 800 grit. Wet and Dry grinding paper and then polished with a silicon-free car polish or with hard-wax, using a polishing machine.

9. Repair of Metal Fittings

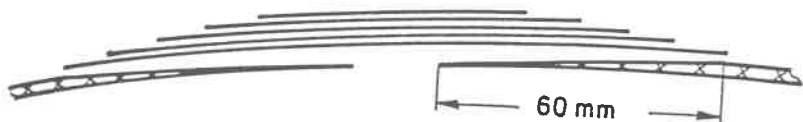
a) Damage to Steel Fittings

Repair of damage to fittings made of steel should only be to accomplished after approved procedures are obtained from manufacturer.

Welded steel fitting (push rods) out of 1.7734.4 BZW 1.0308.1 (St. 35.4). Welding only to be carried out with WIC Welding method (Wolfram-Inert-Gasschmelzanweisung) and with welding material 1.7734.2 (for 1.7734.4) and 1.7324.0 (for 1.0308.0 BZW combination of 1.7734.4 and 1.0308.1)

b) Damage to Aluminium Castings

Repair of Aluminium castings 3.2374.6 (GALSi7 Mgwa) cannot be carried out. Fractured or bent Aluminium castings must be replaced by new ones.

Warning: Bent or chipped Aluminium castings are **not** under any circumstances to be straightened.

c) Main Wing and Fuselage fittings

The main fitting between wing and fuselage (4x in the fuselage) 6 steel balls (\varnothing 6 mm) have contained in each fitting. The balls are forced by a sliding cover through the lock shell into a groove in the moveable lateral axis force bolts in the spar caps thus securing the wings.

Faults of one or more balls, the connecting fitting should be changed.

10. Major repairs

Major repairs are only to be carried out by the manufacturer or by an agent (who has the authorization of the manufacturer.).

Major repairs are:

- **Broken** off wing, fuselage, tailplane, control surface, spar stumps (spar caps)
- **Ripped or torn-out** - Main fittings (in fuselage ϕ 45 x 3, Fitting of the tailplane in fin. In the wing, aileron securing both ϕ 18 mm, joining bearing GE. 20 Spar cap borth ϕ 20 mm).
- Destruction of: Main rib (vertical frame)
- Damage to the GFK laminate (tear, splits, cracks immediately near the main fittings).

11. Construction details of extra equipment attachment fittings

The fittings for the oxygen bottles are built in as standard on the right side of the luggage compartment. Bearing stands and quick action lock can be obtained from the manufacturer.

Other fitting points can be installed by the owner. (Figure 5)

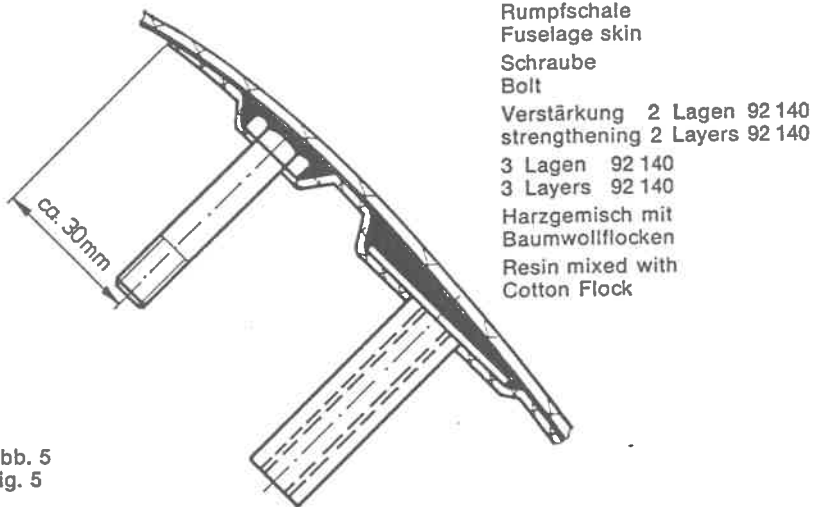

The fitting must be made as shown in the drawing so as to take the weight of the additional equipment. Fittings made in this manner will stand a load 10 g without failure.

When additional equipment is fitted the glider must be re-weighed to see whether the C of G is within the permitted limits.

Blueprints for the installation of radio and oxygen equipments are available from the manufacturer.



FLIGHT MANUAL G 102

ASTIR CS **JEANS**

The Manual belongs to ASTIR CS JEANS

Registration Number Works Number

Manufactured by: Burkhart Grob Flugzeugbau
8939 Mattsies
Flugplatz Mindelheim-Mattsies
West Germany

Owner:

Published: June 1977

This manual should always be kept on board the glider
